

The text 'AGI HI ROLLER' is positioned in the middle-left section of the page. 'AGI' is in a bold, white, sans-serif font, followed by a small stylized wave icon, and 'HI ROLLER' is in a larger, bold, white, sans-serif font. The text is overlaid on a dark green background that features a faint, repeating pattern of stylized gear or roller shapes.

**HI LIFE**

**MODELS 18-72**





# The Problem Solver

## Invest in Efficiency

Hi Roller Enclosed Belt Conveyors are heavy duty, low maintenance, safe, gentle, and efficient. Hi Roller uses unique idlers which allow all bearings to be isolated from internal dust and contaminants. Internally, the troughing belt gently conveys bulk materials to the discharge point. The returning belt slides over an antistatic return liner and continually wipes the bottom enclosure clean of any dust or spilled material. The patented reloading system is the key to a successful system. The absence of this feature can cause product build up, plugging, costly wear, and downtime.

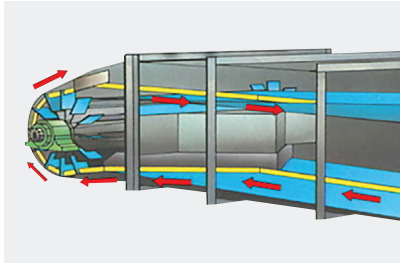

Hi Roller Enclosed Belt Conveyors are designed for the safe, gentle, and efficient handling of dry, bulk materials. This unique, totally enclosed belt conveyor contains dust and spilled material and automatically reloads that material back.

The arrow shows the flow of dust and spilled material back to the tail section where it is directed into reloading vanes, then thrown and deflected back on to the top belt.



The heavy duty tail section incorporates a gasketed sliding box take-up with tensioning and leveling rods. The tail shaft is supported by external pillow block spherical roller bearings. The tail shroud splits at the shaft so that the pulley can be removed without cutting the belt. The shroud comes complete with safety chains and can be removed without the use of tools.



Internally, the spiral winged tail pulley provides constant belt contact for extended belt life. The patented reloading system includes a rugged plow, reloading flippers and a stationary deflector.



# Hi Life



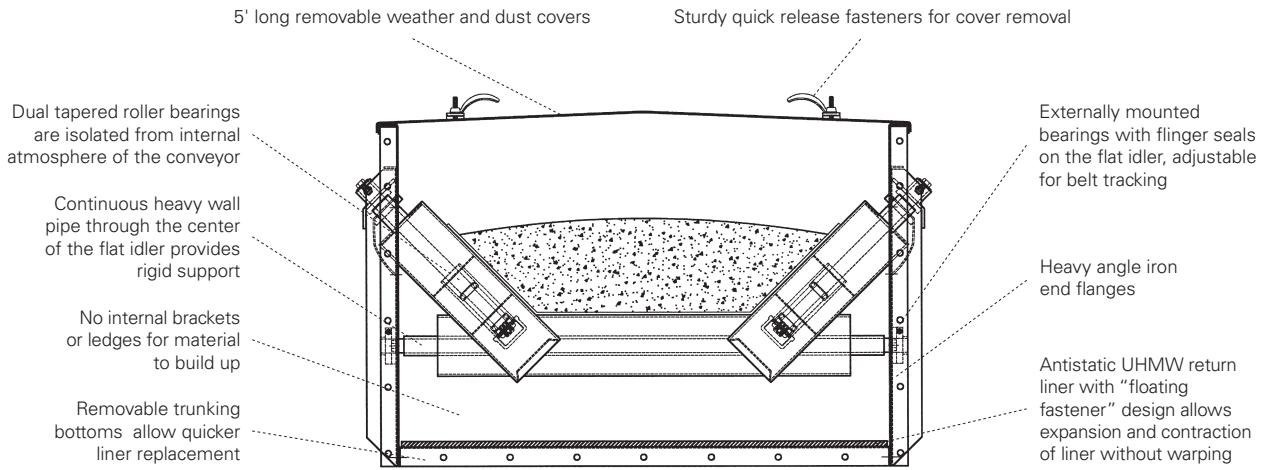

### HI LIFE CAPACITIES

MODEL	UNITS	BELT SPEED IN FEET PER MINUTE							
		350	400	450	500	550	600	650	700
18	BU/HR	3,153	3,603	4,054	4,504	4,955	5,405	5,856	6,306
	CF/HR	3,924	4,484	5,045	5,606	6,166	6,727	7,287	7,848
	MTPH	85	98	110	122	134	146	159	171
24	BU/HR	7,263	8,301	9,339	10,376	11,414	12,451	13,489	14,527
	CF/HR	9,039	10,330	11,622	12,913	14,204	15,496	16,787	18,078
	MTPH	197	225	253	281	309	337	365	394
30	BU/HR	12,016	13,733	15,450	17,166	18,883	20,600	22,316	24,033
	CF/HR	14,954	17,091	19,227	21,364	23,500	25,636	27,773	29,909
	MTPH	326	372	419	465	512	558	605	651
36	BU/HR	17,539	20,045	22,551	25,056	27,562	30,068	32,573	35,079
	CF/HR	21,828	24,946	28,064	31,183	34,301	37,419	40,537	43,656
	MTPH	475	543	611	679	747	815	882	950
42	BU/HR	24,970	28,538	32,105	35,672	39,239	42,806	46,374	49,941
	CF/HR	31,076	35,515	39,954	44,394	48,833	53,273	57,712	62,151
	MTPH	676	773	870	966	1,063	1,160	1,256	1,353
48	BU/HR	33,271	38,023	42,776	47,529	52,282	57,035	61,788	66,541
	CF/HR	41,405	47,320	53,235	59,150	65,065	70,980	76,895	82,810
	MTPH	901	1,030	1,159	1,288	1,416	1,545	1,674	1,803
54	BU/HR	40,409	46,182	51,954	57,727	63,500	69,272	75,045	80,818
	CF/HR	50,289	57,473	64,657	71,841	79,025	86,209	93,393	100,578
	MTPH	1,095	1,251	1,408	1,564	1,720	1,877	2,033	2,189
60	BU/HR	49,749	56,856	63,963	71,070	78,177	85,284	92,391	99,498
	CF/HR	61,913	70,757	79,602	88,446	97,291	106,136	114,980	123,825
	MTPH	1,348	1,540	1,733	1,925	2,118	2,310	2,503	2,696
66	BU/HR	57,809	66,067	74,325	82,584	90,842	99,101	107,359	115,617
	CF/HR	71,943	82,220	92,498	102,776	113,053	123,331	133,608	143,886
	MTPH	1,566	1,790	2,014	2,237	2,461	2,685	2,908	3,132
72	BU/HR	70,122	80,139	90,157	100,174	110,191	120,209	130,226	140,244
	CF/HR	87,267	99,733	112,200	124,666	137,133	149,600	162,066	174,533
	MTPH	1,900	2,171	2,442	2,714	2,985	3,257	3,528	3,799

FPM Feet Per Minute | BPH Bushels Per Hour | CFPH Cubic Feet Per Hour | MTPH Metric Ton Per Hour (Based upon 769 Kg Cubic Meter)  
 Capacities are based upon horizontal installation and even belt loading.

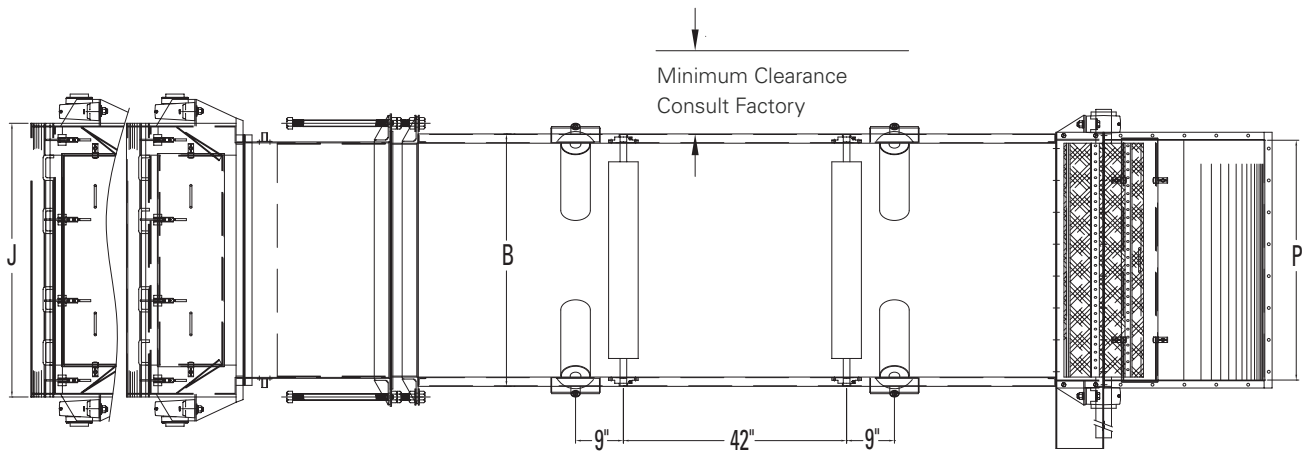

\*\* Overall width determined by bearing and drive size.

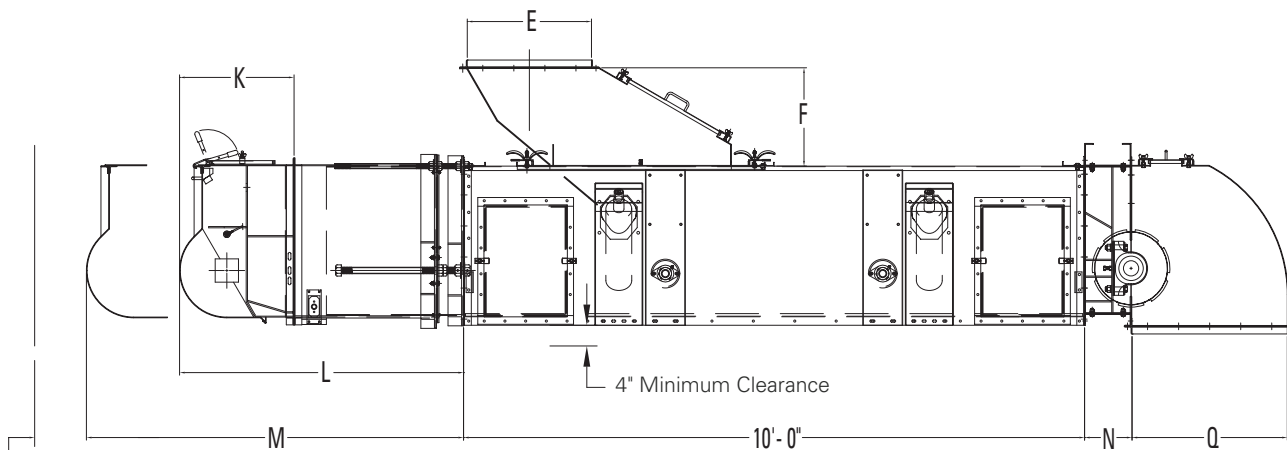

10" Minimum Clearance M18-M48  
18" Minimum Clearance M54-M72

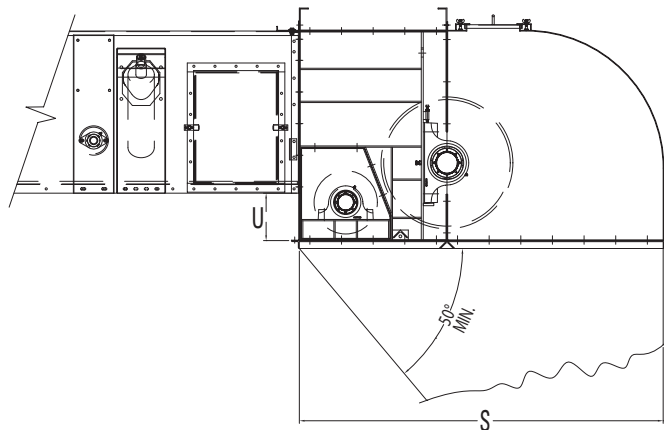
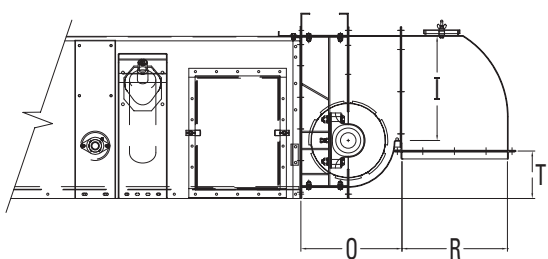

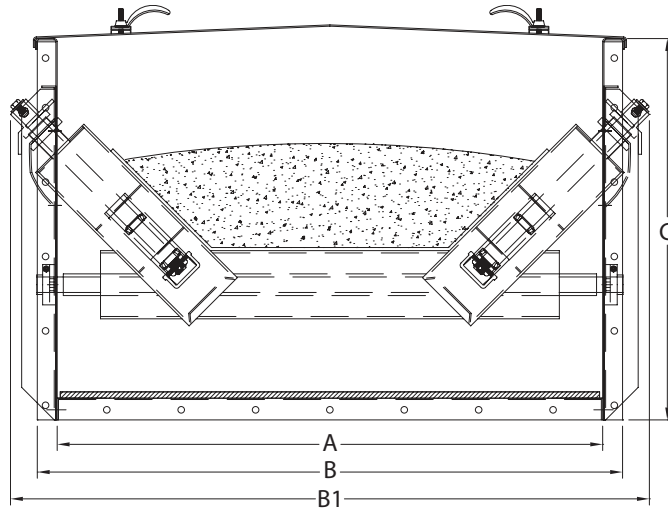

## HI LIFE DIMENSIONS

### HI LIFE MODELS

DESCRIPTIONS	18	24	30	36	42	48	54	60	66	72
A Trunking Width (Inside)	20	26	32	38	44	50	56	62	68	74
B Trunking Width (Outside)	23 1/2	29 1/2	35 1/2	41 1/2	47 1/2	53 1/2	59 1/2	66 3/4	72 3/4	78 3/4
B1 Trunking Width (Outside Channels)	29 3/4	33 1/2	39 1/2	45 1/2	51 1/2	57 1/2	61 1/4	68 3/4	74 3/4	80 3/4
C Trunking Height (Outside)	23 3/4	25 3/4	26 3/4	27 3/4	29 3/4	30 3/4	38	40	44	49 1/4
D Inlet Opening Width	8	10	16	24	34	44	54	54	54	60
E Inlet Opening Length	24	30	30	30	30	30	30	36	42	48
F Standard Inlet Height	19	19	19	19	19	19	19	24	24	24
G Cleanout Inlet Height	1 5/8	1 5/8	1 5/8	1 5/8	1 5/8	1 5/8	1 5/8	1 5/8	1 5/8	1 5/8
H Inlet Cover Length	48	54	54	54	54	54	54	60	60	60
I Lo Profile Opening Height	12 3/4	14 3/4	15 3/4	16 3/4	18 3/4	19 3/4	23 3/4	25 1/2	29 1/2	32 3/4
J Tail Width (Less Bearings)	27 1/2	33 1/2	39 1/2	45 1/2	51 1/2	57 1/2	63 1/2	69 1/2	75 1/2	85 1/2
K Stub Tail Length	22 1/8	22 1/8	22 1/8	22 1/8	22 1/8	22 1/8	29	32 1/8	32 1/8	35 1/2
L Take-Up Length Retracted	Take-up length + 36 7/8						Take-up length + 43 3/4			Take-up length + 47 3/4
M Take-Up Length Extended	Take-up length x 2 + 36 7/8						Take-up length x 2 + 43 3/4			Take-up length x 2 + 47 3/4
N Std Head Length	9	9	9	9	9	9	12	14	14	14
O Lo Profile Head Length	19	19	19	19	19	19	25 3/8	NA	NA	NA
P Discharge Opening Width	21 1/8	27 1/8	33 1/8	39 1/8	45 1/8	51 1/8	57 1/8	63 1/8	69 1/8	75 1/8
Q 90 Degree Discharge Length	28	28	28	30	30	30	44	48	54	56
R Lo Profile Discharge Length	18	18	18	20	20	20	30	NA	NA	NA
S Snubber Discharge Length	69	69	69	69	69	69	83	96	96	102
T Discharge To Trunking Bottom	9	9	9	9	9	9	12	NA	NA	NA
U Discharge To Trunking Bottom	9 1/4	9 1/4	9 1/4	9 1/4	9 1/4	9 1/4	13	14	14	15 1/4

The above dimensions are stated in inches. Designs and specifications are subject to change without notice. Hi Roller Conveyors are manufactured under several Patents and Pending Patents.

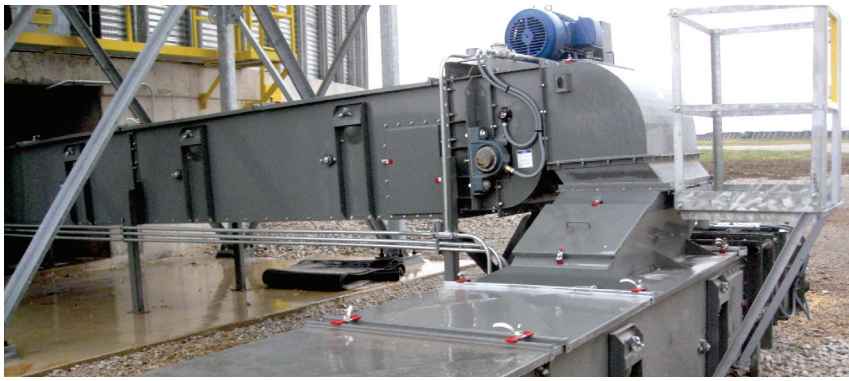



The AGI Hi Life idlers have non rotating spindles that enter the hub on the outer end of the troughing idlers. The dual tapered roller bearings are deeply embedded in the center of the roller and are isolated from any exposure to the dust and contaminants on the inside of the enclosure. The center of the idler is isolated by an air space to prevent any conduction of heat from a failed bearing. Hubs are enclosed so that they cannot leak grease. Grease seals are on the upper end of the troughing idlers so gravity prevents the grease from leaking out.

The offset spacing of the three-piece idler reduces power requirements and induces less load support stress. The three-piece idler allows for a deeper trough than other spool shaped idlers used on the other Hi Roller models. This also eliminates slippage on the spool shaped idler. This means that the Hi Life Idler will provide more capacity for the belt width and greatly reduce the idler wear. The Hi Life is the ultimate in dust free long life conveying.

**FEATURES**

- Gradual Inclines and Sharp Upbends
- Stationary Intermediate Discharge Trippers
- Moveable Discharge Trippers and Plows
- Reversible Conveyors (Reloading in Both Directions)
- Two-way Discharge Valves
- Proportioning Gates
- Worm Gear Reduction Manual Belt Tensioners
- Load Cells for Belt Tension Monitoring
- V-Wheel Tail Supports
- Shuttle Conveyors
- Split Trunking to Facilitate Belt Splicing
- Quick-Draw Idlers and Grease Tubes
- Floor Supports and Hanger Brackets
- Cut-outs for Belt Misalignment Sensors
- Motion and Plug Sensors
- Galvanized and Stainless Steel Construction
- Metric Components
- Intermediate Sidewall Inspection Doors

AGI Hi Roller is more than a manufacturer. We can review your project on-site, make recommendations, prepare proposal drawings, and provide start-up assistance. We have found that a successful installation relies upon a clear understanding of the process, from the spouting and placement of the material on to the belt to the discharge and spouting out the other end. Put our design experience to work for you.

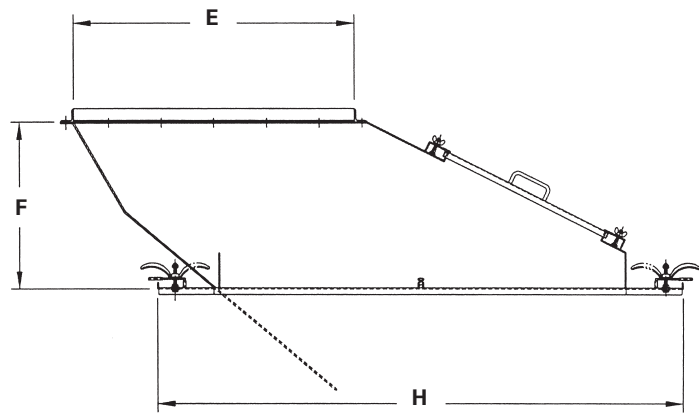
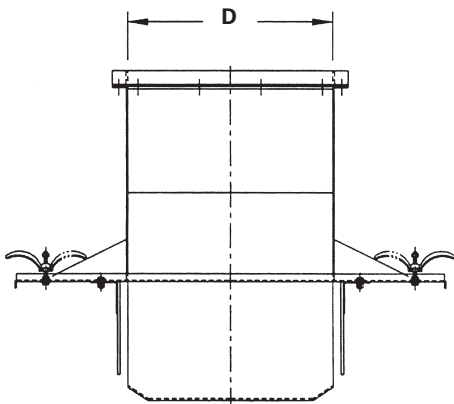

**Above** Typical initial inlet with fixed skirts

**Below** Typical cleanout inlet with swing-down skirts

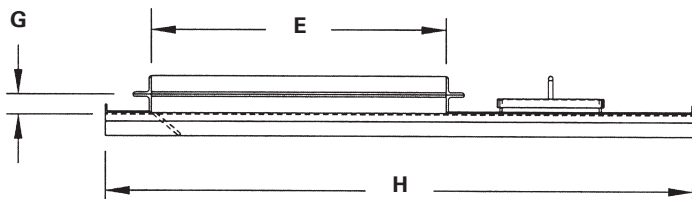
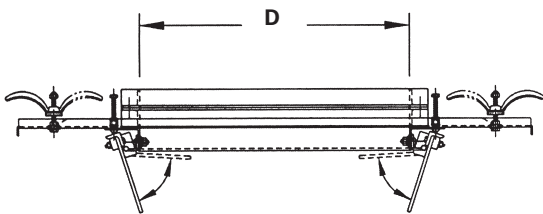

Inlet heights and lengths can be customized to your specific applications

# Installations



# Product Line

Belt Conveyors have long been known as the most gentle, efficient and durable means of conveying materials.

## AGI HI ROLLER Conveyors

are custom built to your specific requirements. Some of our more popular models include:

### Hi Roller

Available in belt widths from 18" to 54", this is our original model. The unique bell-shaped carrying idler provides the trough for the belt and utilizes two external bearings as opposed to the six internal bearings associated with a conventional idler. The bell-shaped idler also has built-in self-aligning characteristics for both single and bi-directional conveyors.

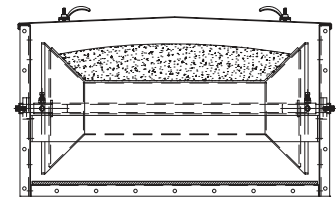

---

### Hi Life

Available in belt widths from 18" to 72", the Hi Life utilizes possibly the heaviest, longest life, most reliable conveyor idler available. Resembling a conventional conveyor idler, the Hi Life idler is much thicker, the bearings are much larger, and there are no brackets or bearings exposed to the internal atmosphere of the conveyor housing.

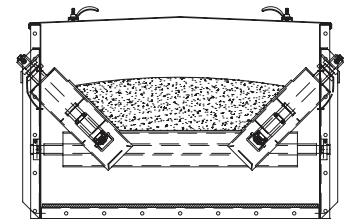

---

### Mini Roller

Available in belt widths from 16" to 36", the Mini Roller includes all the benefits of the Hi Roller in a lower profile design. The bell shaped carrying idler, head, and tail pulleys all have a smaller diameter. This conveyor is well suited for low capacities.

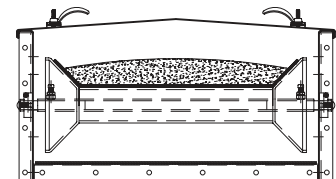

---

### Lo Roller

Available in belt widths from 16" to 36", the Lo Roller utilizes a flat carrying idler to support the loaded weight of the belt and relies on the UHMW side slides to form a trough for the belt. The design provides continuous belt support and creates a seal at the edges.

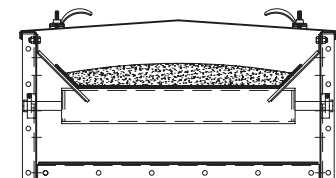

---

Hi Roller specializes in the custom design of enclosed belt conveyors to match your specific application. In addition to our standard models, we can also customize conveyors for your most unique applications. The Hi Bulk is an enmasse belt conveyor designed to move large quantities of material in a limited space. The Consignor is a belt conveyor with a totally enclosed, fully automated moveable discharge tripper. We look forward to helping you solve your most difficult material handling problems.



AGI is a global leader in supplying farm and commercial customers with the manufacturing, planning, and engineering of full equipment solutions for grain, seed, fertilizer, feed, and food. AGI's expertise enables the storage, blending, mixing, conveying, conditioning, processing, and protection of agricultural products and inputs worldwide.

**Your safety is our highest priority.**

Please read and understand the operator's manual and safety decals before using. Use and maintain products properly, and do not modify. Keep guards in place when operating and follow all product manuals and safety decals. For all AGI products, if guards, safety decals, or manuals are damaged or missing, contact your AGI sales or dealer representative for replacements. Images and information contained in this brochure are presented for general information.

AGI and the furrows symbol are trademarks belonging to Ag Growth International Inc.

198 Commerce Drive, Winnipeg, Manitoba, Canada R3P 0Z6  
P 800.328.1785 | sales@hiroller.com | aggrowth.com/hiroller

     @aggrowthintl

**AGGROWTH.COM**