



ELECTRIC CLUTCH INSTALLATION (TRIPLE-GROOVE PULLEY) FOR STX/R10-51 AUGERS

INSTALL THE ELECTRIC CLUTCH

Note: *The instructions in this manual assumes installation during assembly of a new auger. If this kit is installed after initial auger assembly, some procedure detail may differ.*

- Refer to Figure 1 for installation detail for typical engines.
- Refer to Figure 2 for installation detail for Vanguard engines.

1. Mount the hydraulic pump bracket (1) and stop bracket (11) to the engine plate using 3/8" x 1-1/4" bolts (2), lock washers (3) and flat washers (4).



- **For typical engines:** Use the top engine block bolt holes only. Fasten bolts loosely to allow for adjustment of the stop bracket to the clutch before tightening.
- **For Vanguard engines:** Use the top engine block bolt holes for the stop bracket (fasten loosely to allow for adjustment to the clutch before tightening), and the bottom bolt holes for the pump bracket. Use two 1/2" lock washers (5) to create a level mount between the engine block and pump bracket.

2. Slide the square shaft key (6) and lower pump pulley (7) onto the engine shaft.

3. Slide the electric clutch (8) onto the engine shaft and secure it with a 7/16" x 3" bolt (9) and lock washer (10).

Note: *When properly adjusted the electric clutch should be tight and unable to slide on the shaft.*

4. Connect all belts.
5. Adjust the stop bracket (11) and clutch (8) so that the bracket fits into the clutch case slot to prevent the clutch from rotating.
6. Tighten the stop bracket bolts, and ensure that all other bolts are tight.

Figure 1 Installing the Electric Clutch, Typical Engine

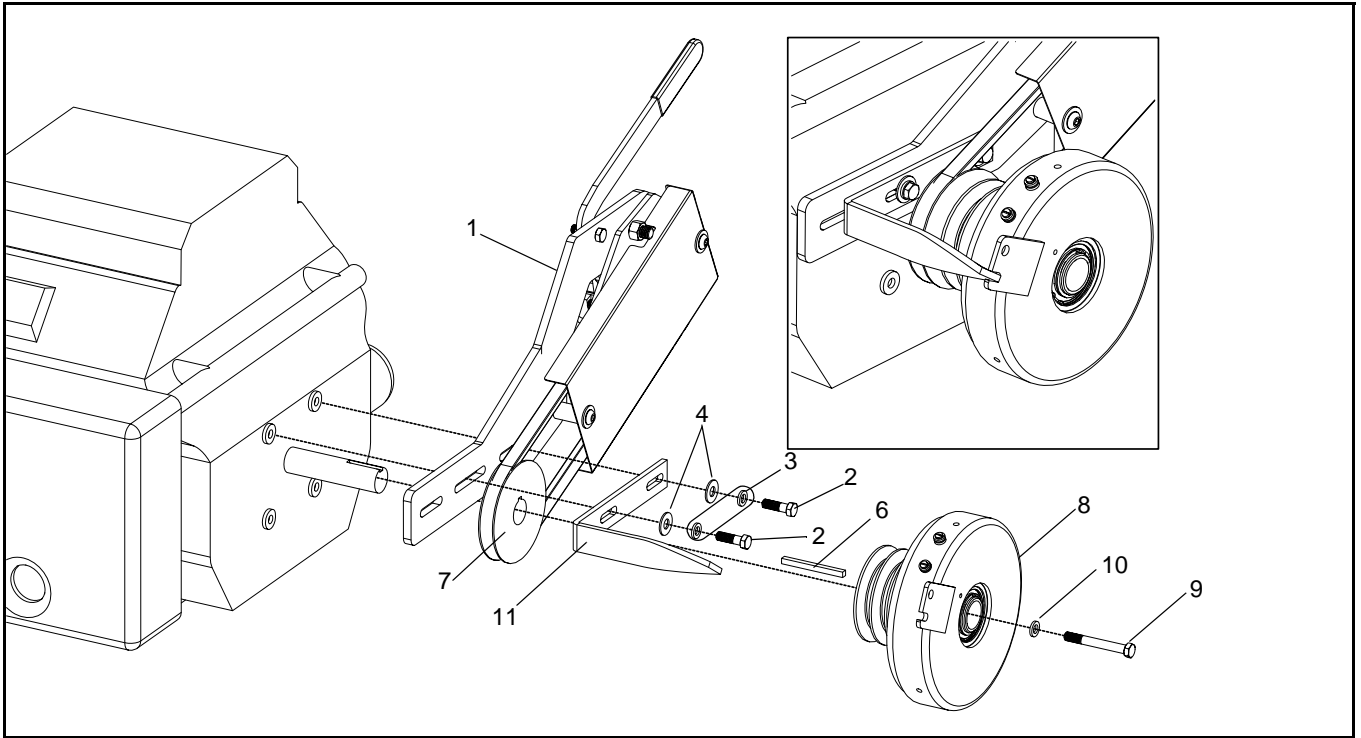
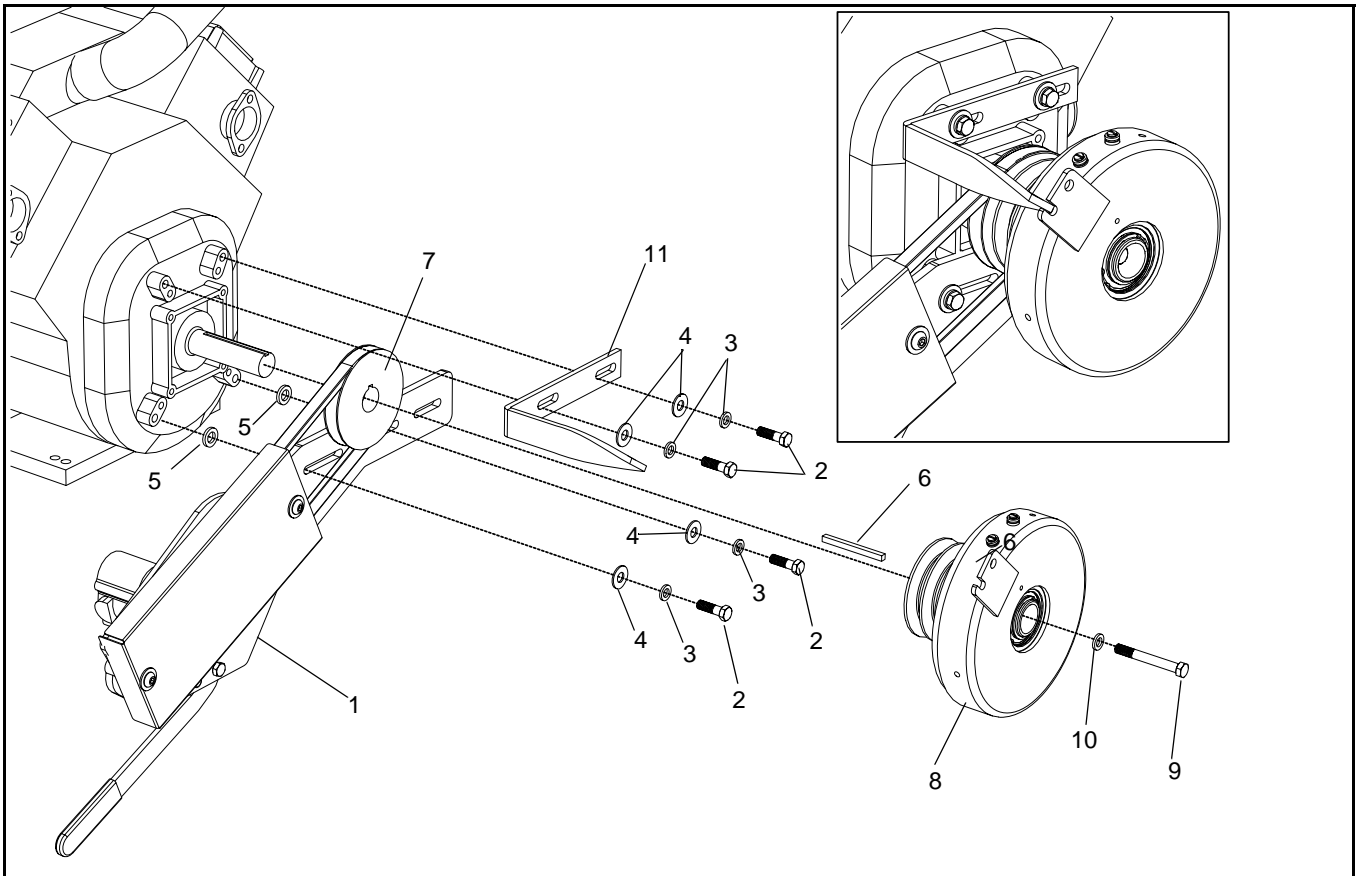

Figure 2 Installing the Electric Clutch, Vanguard Engine



WIRE THE ELECTRIC CLUTCH

1. Remove (cut off) the clutch harness connector that includes a connection clip on one side (see Figure 3 below).

Figure 3 Connector with Clip



2. Prepare the cut end for connection by trimming harness jacket and wire insulation as needed, crimp ring terminals to the two wires on that end, and connect them to the screw terminals on the clutch (it does not matter which wire connects to which terminal).
3. Complete the remaining electrical connections, using 14 gauge crimp connectors (splice, spade, and ring terminal) as needed (see wiring diagrams in Figure 4 and Figure 5):
 - connect the green switch cable wire to one of the clutch harness connector terminals;
 - connect the black switch cable wire to the fuse, and from there to 12 VDC power;
 - connect the remaining clutch harness connector terminal to ground.
4. Test the switch to ensure that the electric clutch engages and disengages properly.
5. Use electrical tape to seal and secure any electrical connections that might require weather-proofing.
6. Secure the electrical cable to a frame cable-ties or other equivalent fasteners to prevent accidental disconnection of wiring if the cable is pulled tight.
7. Secure the cable when not in use.

Figure 4 Switch Detail

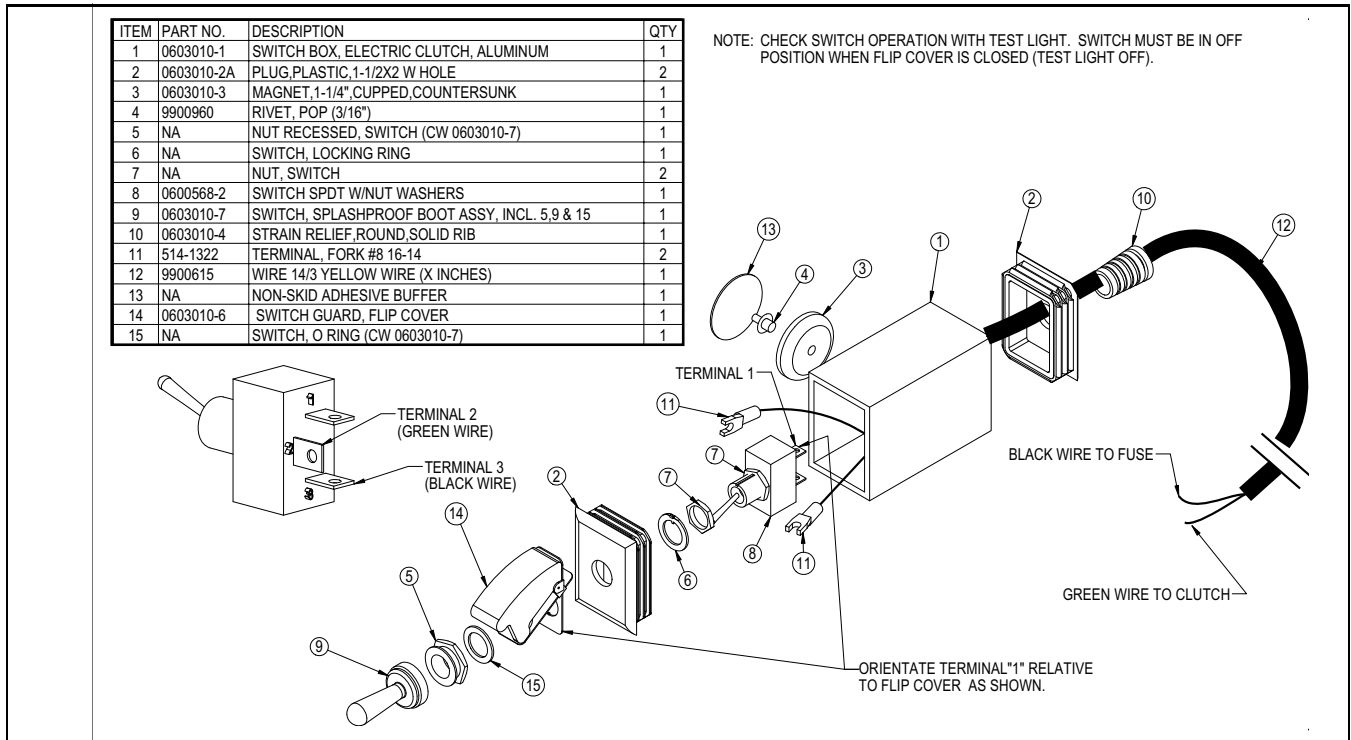

Figure 5 Electric Clutch Wiring Diagram

