

ETM 300

TESTATA DI COMANDO DRIVING HEAD

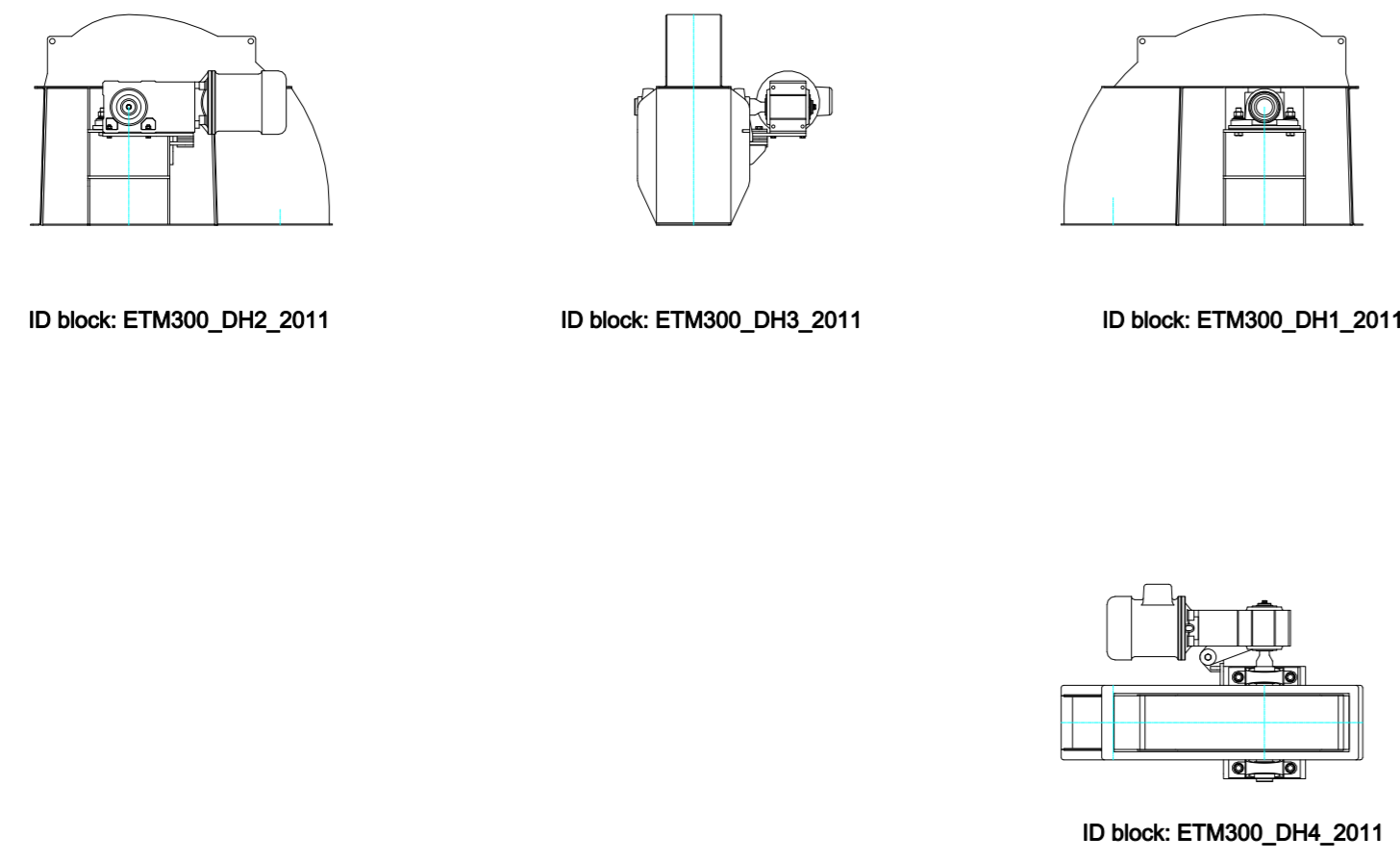

WEIGHT
PESO
[kg]
224

CANNE STANDARD STANDARD LEGS

L=2900

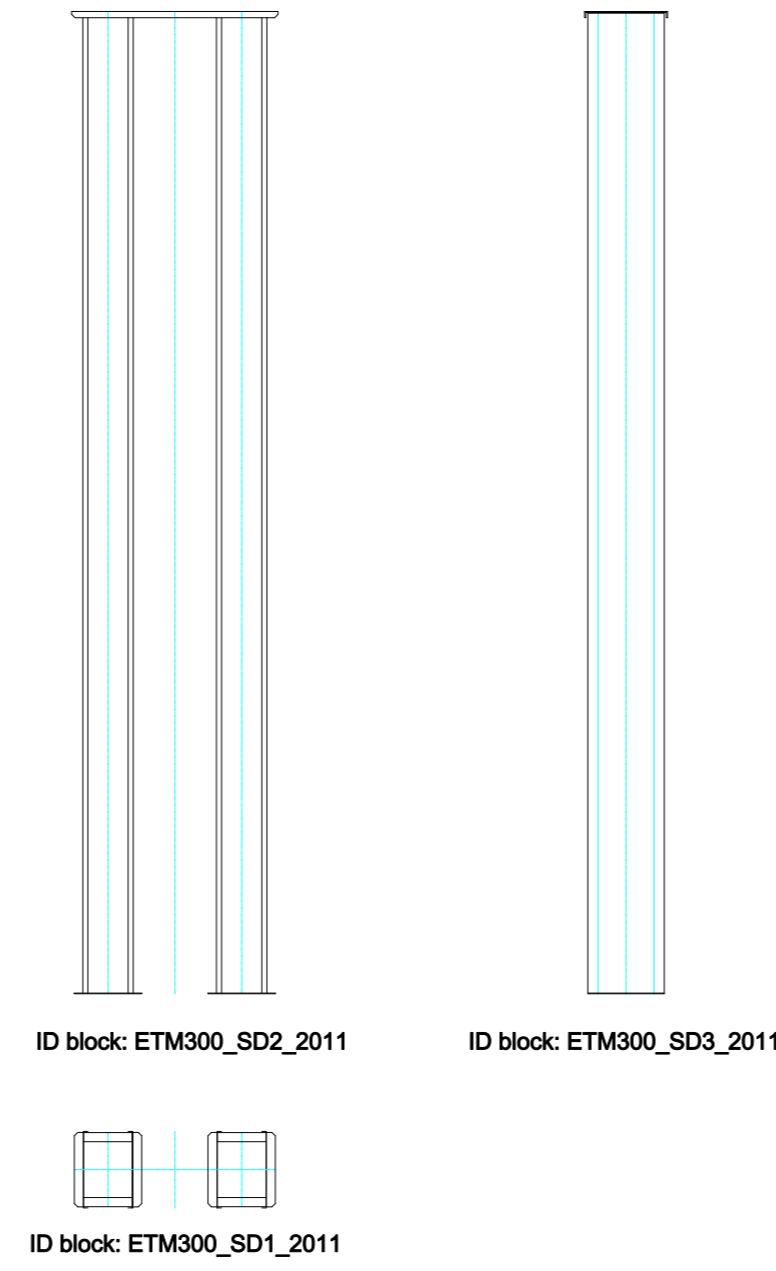

WEIGHT
PESO
[kg/m]
45

L=2400

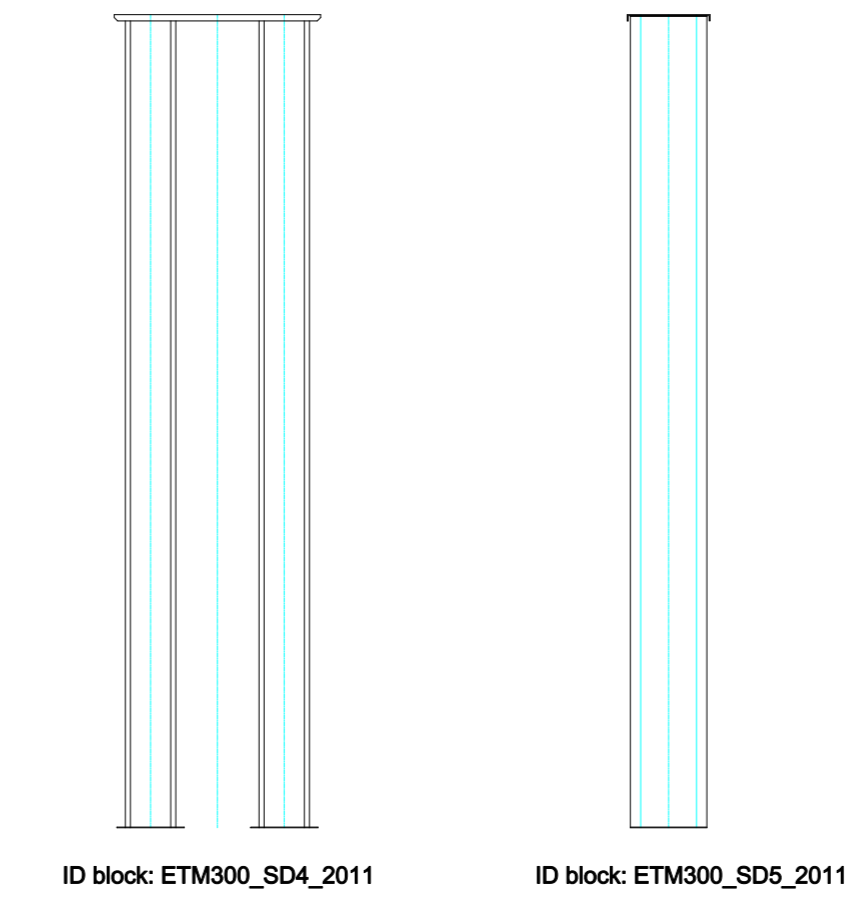

L=1900

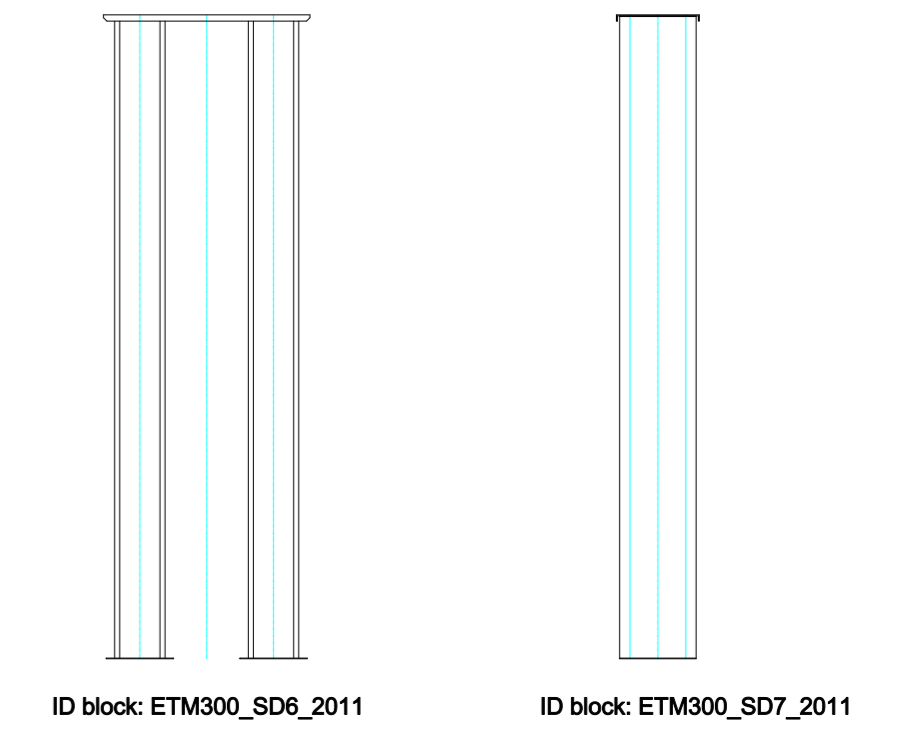

PIEDE TAIL

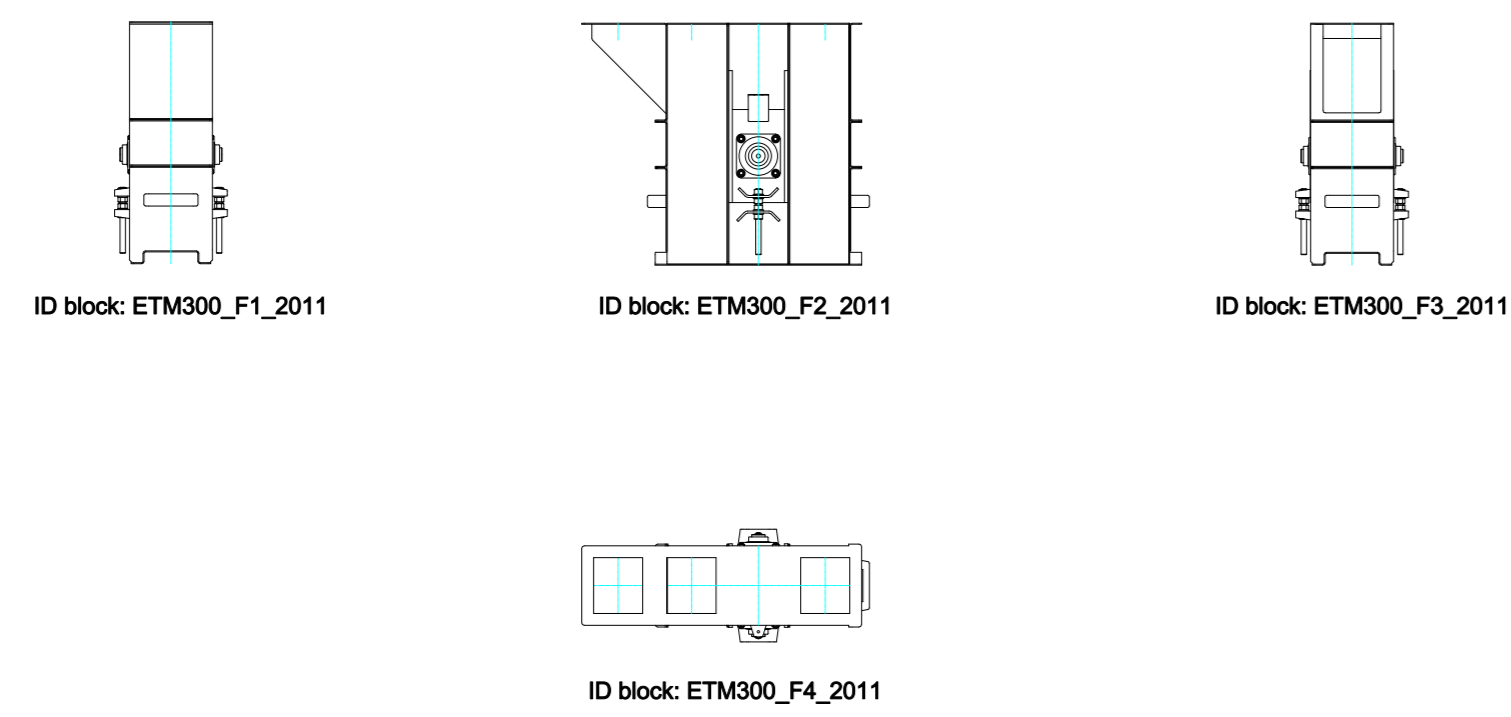

WEIGHT
PESO
[kg]
75

L=1400

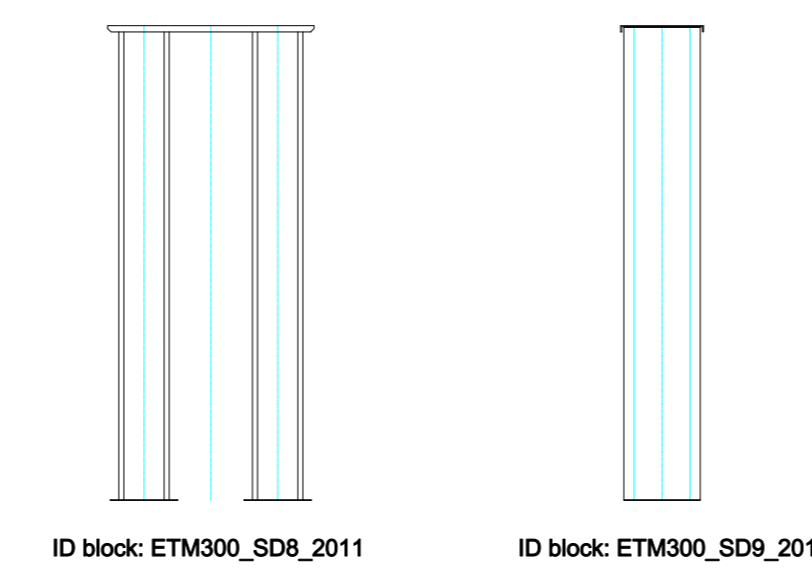

L=900

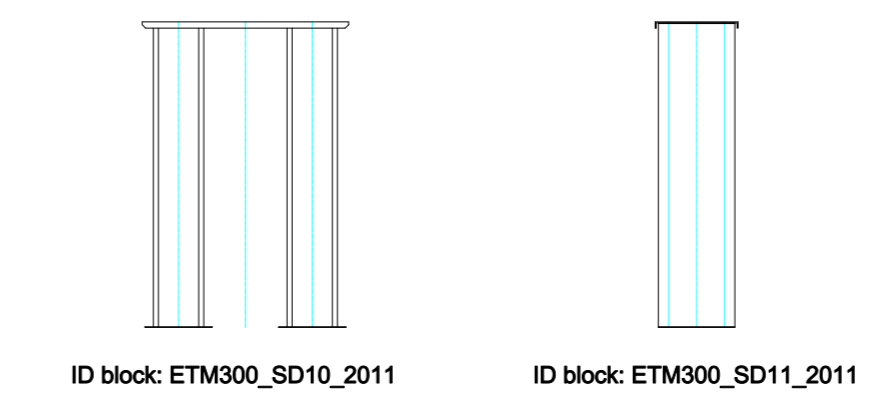

L=400



CANNA D'ISPEZIONE INSPECTION LEG

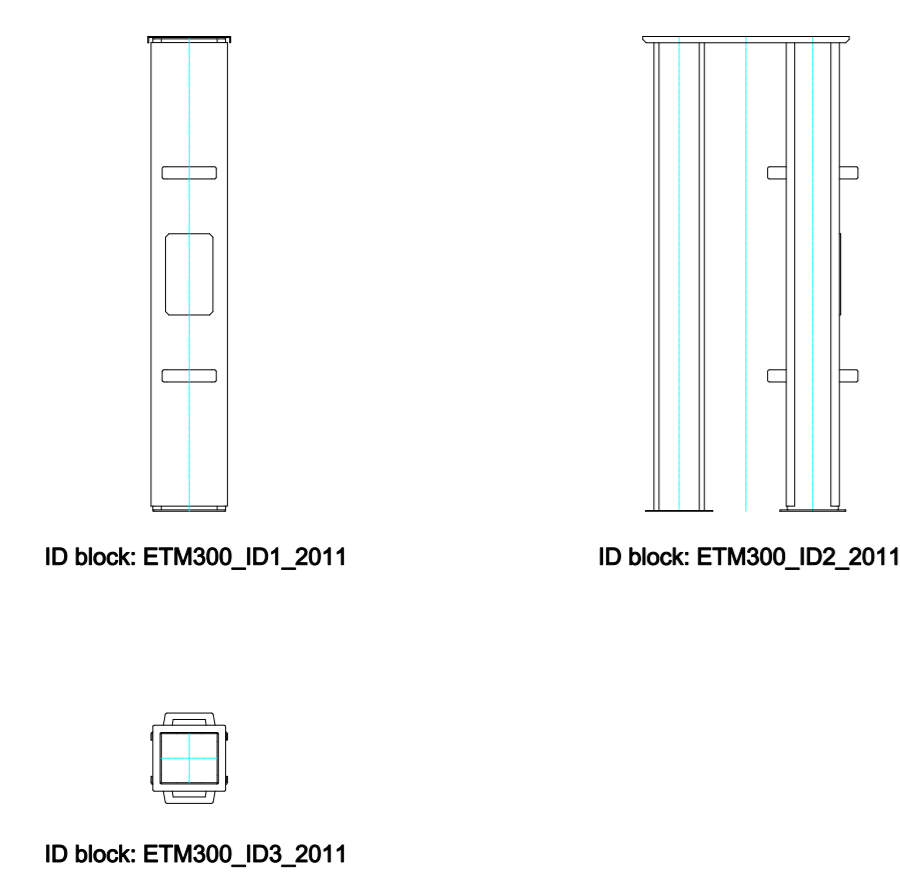

DISTANZIALE CANNE SPACER BETWEEN LEGS

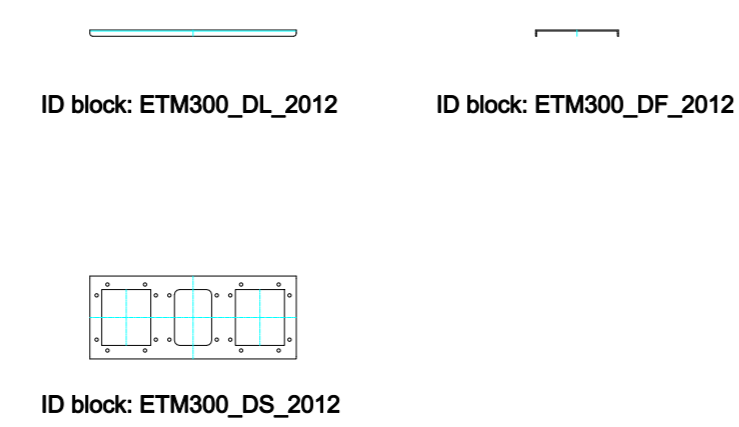

CONTROLLO SBANDAMENTO NASTRO BELT ALIGNMENT DUCT L=400

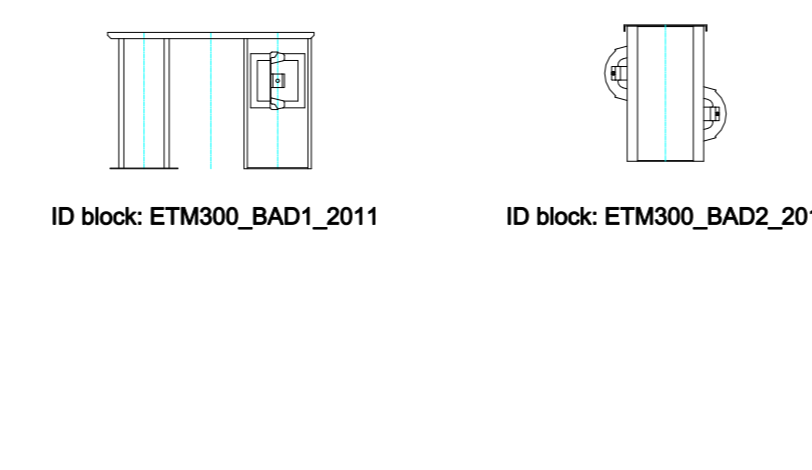

TRAMOGGIA DI SCARICO 160x160 OUTLET HOPPER 160x160

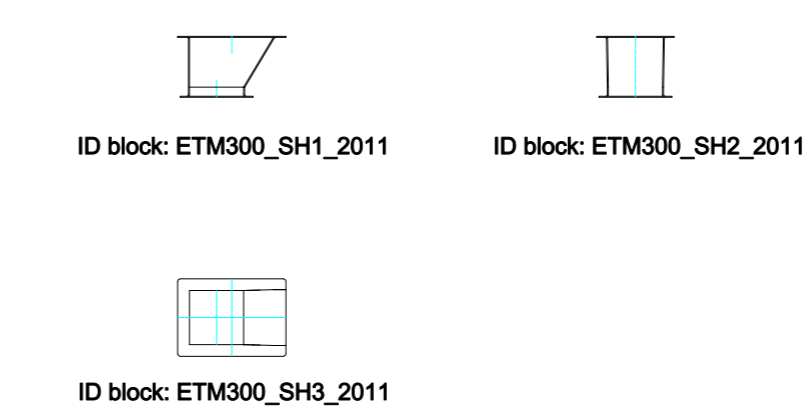

CANNA DI ASPIRAZIONE ASPIRATION LEG

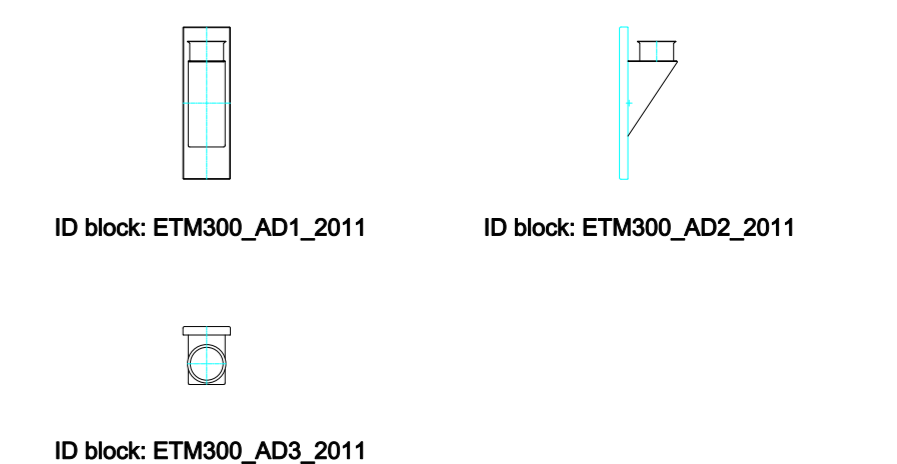

0	EMMISSIONE / EMISSION	Descrizione modifica:	U.T. PTM	01/12
Scale	1:1	Object	DATA	01/01/2012
AZIENDA CON SISTEMA DI GESTIONE PER LA QUALITÀ CERTIFICATO DA UNI EN ISO 9001:2008		SERIE ETM 300 TECHNICAL DRAWING BUCKET ELEVATOR TYPE ETM 300	PRODUZIONE: TECNOLOGIE ANIMATI 38060 ESTE (PD) ITALY Via Mare Tronco, 10 Tel. 0429-801001 Fax 0429-801002 Email: tech@animati.com	

