

ASSEMBLY, INSTALLATION AND OPERATION MANUAL

312 SOUTH HWY. 73, PO BOX 398
FALLS CITY, NE 68355-0398
800-500-9777

Revision Date 06/26/08

Index

Introduction	3
Bin Preparation	4
Layout	5
Assembly	6
Perforated Top Plate	9
Preparing For Concrete	10
Concrete Ridges	11
Exterior Ducting.....	12
Feeder Systems	13
Parallel Discharge Troughs	16
Operating The System	18
Filling bins	18
Aeration.....	18
Bin unloading	18
Installation Completion Checklist.....	19

Introduction

The AIRLANCO AIRAUGER™ system is designed to both aerate and unload grain storage bins whether they discharge from the center, the side, or from multiple discharge points.

It does this by way of a valved ducting system that allows the operator to send a controlled volume of air to all of the ducts at once for aeration, or a maximum volume of air to a single duct for bin unloading.

The AIRAUGER™ also eliminates the need for potentially dangerous bin entry by facility personnel, since there are no controls or moving parts inside the bin.

Please read the entire manual before beginning installation.

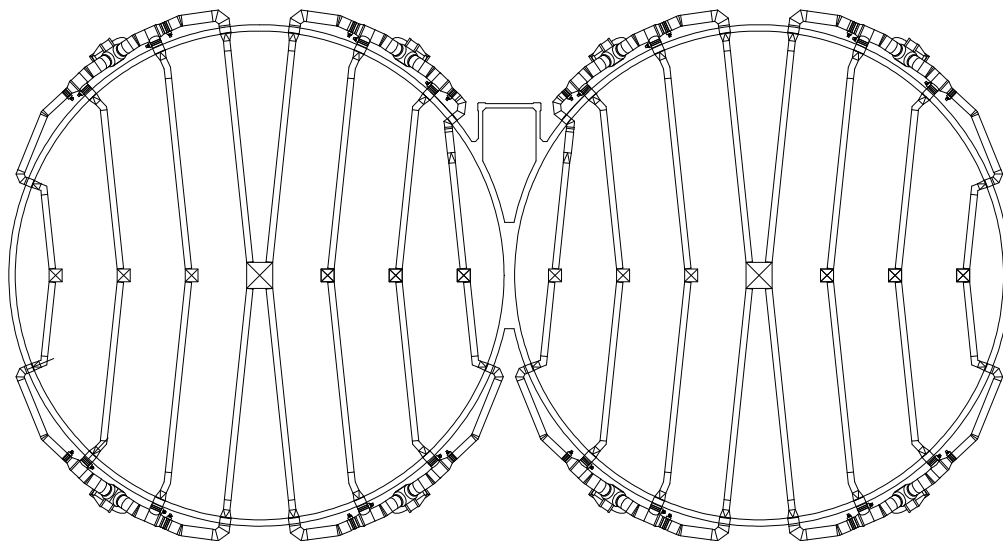

Bin Preparation

Refer to the plan drawing included with your shipment to determine where to place blockouts in new construction, or where to cut openings in an existing bin. Blockouts or openings should be large enough to accommodate the required ducting and oversized to allow for adjustments should they be required. The bin openings will be grouted once the ducting is in place.

The bin floor should be reasonably level and smooth. If there are cracks in the bin floor, it is not necessary to repair them as long as the cracks have not heaved. It will be necessary to repair any irregularities in the bin floor that will interfere with the bottoms of the AIRAUGER™ troughs sitting level on the floor.

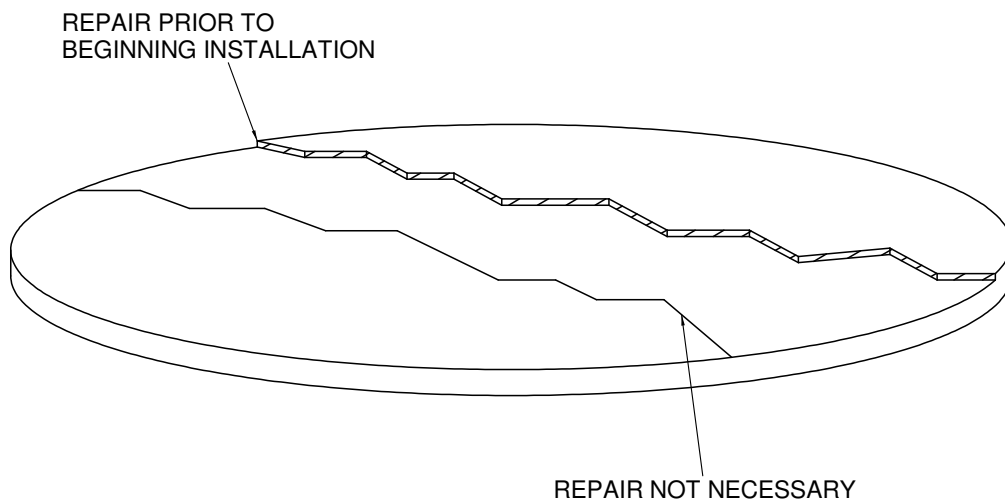

Sweep the bin floor clear of all debris prior to beginning the installation.

Layout

Unpack all parts from pallets and lay out according to the included site-specific installation drawing. The reference number written on each part will correspond to a bubble number on the drawing. The included reference number list gives a reference number, description of part and the quantity of each part required.

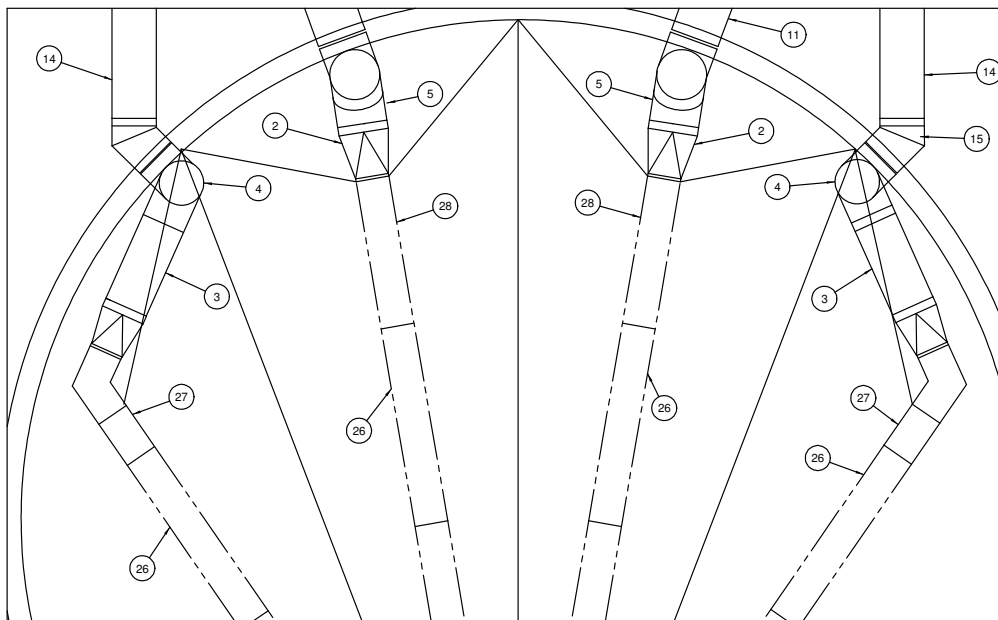

EXAMPLE

Lay out and match all parts to the installation drawing before assembling any parts. Note that pallets are not packed by bin. All of the parts for a single bin will likely be found on multiple pallets.

Note that the narrow end of the trough will be nearest the bin discharge. The deepest end of the trough will be at the duct opening at the bin wall.

Assembly

Once the parts are laid out, begin assembling the trough sections as shown, beginning at the discharge (narrow) end and working back toward the air supply transition.

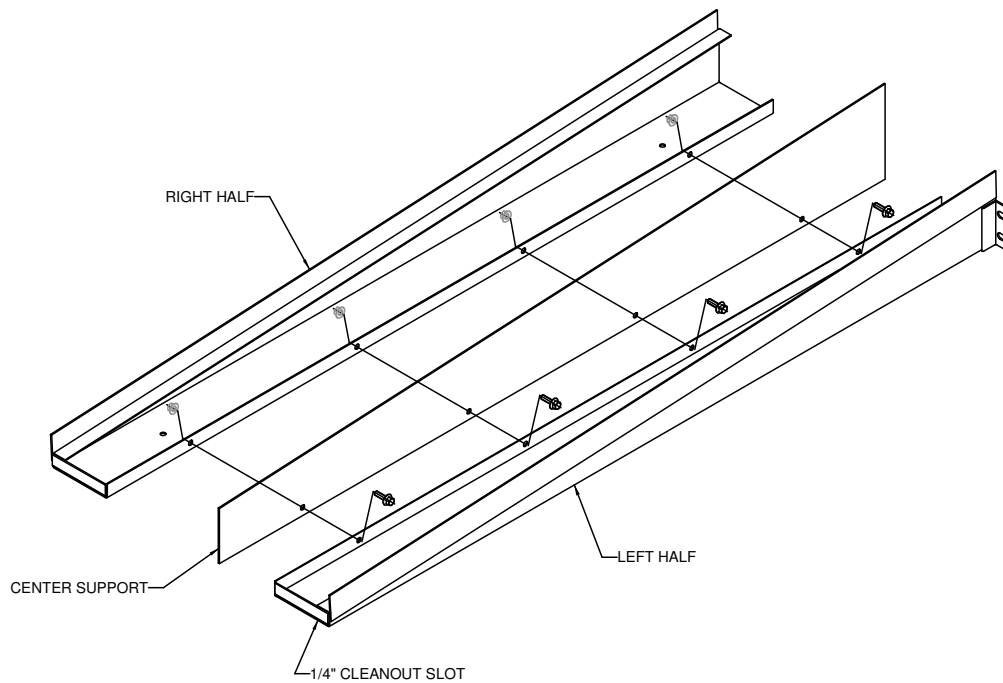

INDIVIDUAL SECTION ASSEMBLY

ASSEMBLE EACH SECTION AS SHOWN USING 3/8 X 3/4 WHIZ-LOK BOLTS AND 3/8 WHIZ-LOK NUTS.

DISCHARGE END SECTION SHOWN. ALL SUBSEQUENT SECTIONS ARE ASSEMBLED IN LIKE MANNER.

Once the left and right trough sections are bolted together, bolt the completed sections together end to end. Refer to the installation drawing to determine where each section fits.

Finally, bolt the air supply transition to the end of the AIRAUGER™ trough.

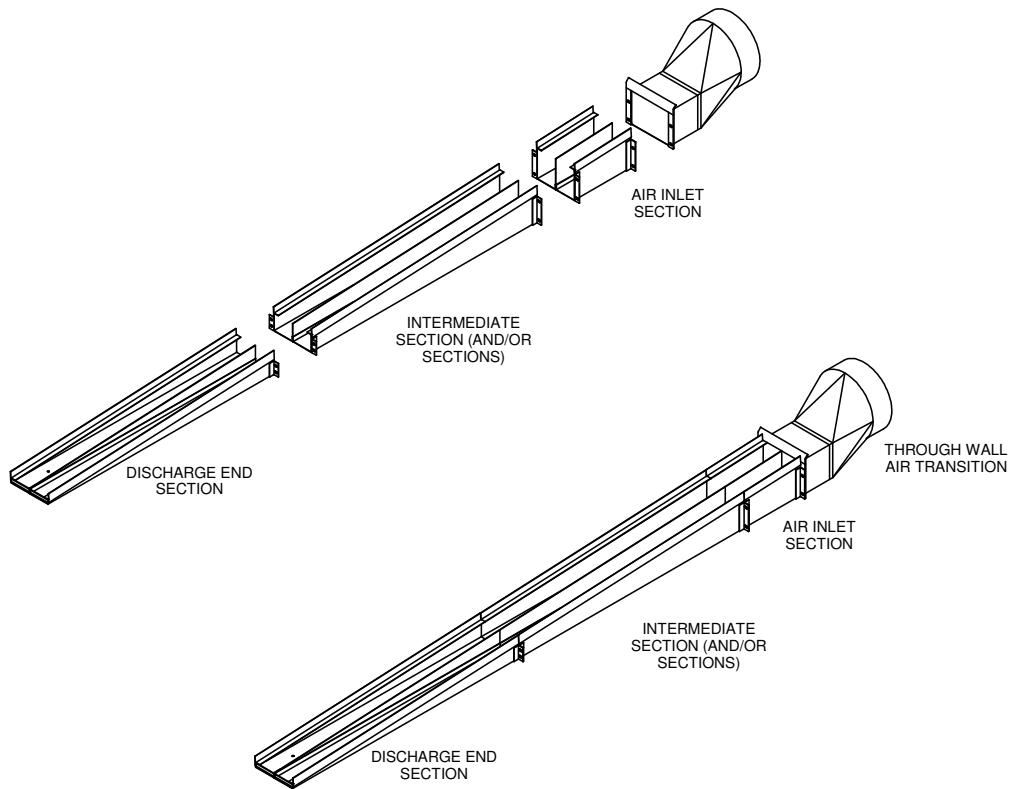

Position the narrow (discharge) end of the trough so that it is back approximately 1" from the bin outlet sump.

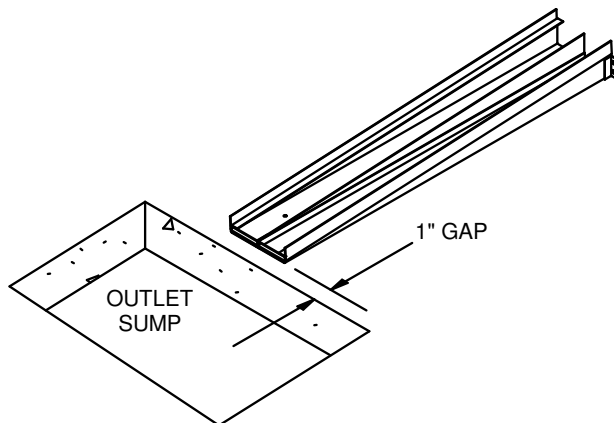

If the trough meets the discharge at an angle, It may be necessary to chip away some concrete to facilitate grain flow from the trough into the outlet sump.

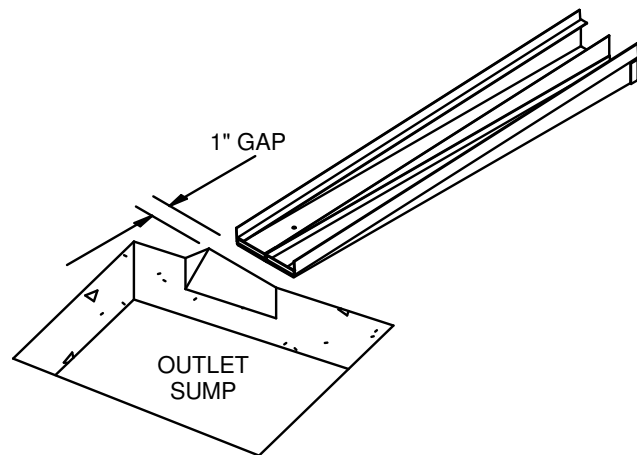

Once all of the trough sections have been assembled and bolted to the air supply transitions, make sure that all of the trough is supported adequately from below. If there are any gaps under the trough, fill them with steel shims. It is critical that the troughs are supported along their entire length. Pay special attention to the joints between the trough sections.

When you are satisfied that the troughs are properly placed in the bin and supported adequately, anchor the troughs to the bin floor using concrete expansion anchors.

NOTE: If you have any fit problems, contact AIRLANCO. Never cut trough for any reason unless instructed to do so by an AIRLANCO representative.

Perforated Top Plate

Thoroughly inspect all trough to make sure it is clean and free of any debris prior to installing perforated top plate.

Begin installing top plate at the narrow (discharge) end of the AIRAUGER™ trough. The top plate is directional, and must be installed with the smooth surface up and the air scoops down and open in the direction of the air flow.

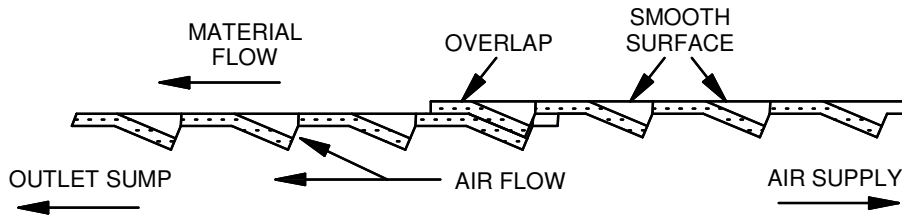

The perforated top plate is attached to the trough with 1/4" x 3/4" self-drilling screws. Overlap top plate sheets one row of perforations as shown above, and install self-drilling screws approximately 1" back on both sides of overlap. Field drilling may be required to ensure proper overlap and screw spacing.

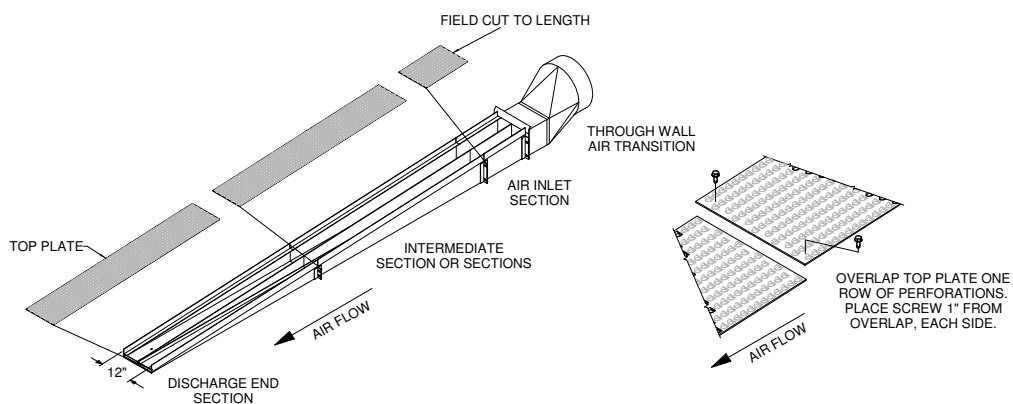

Note the 12" inside trough spacing. Use bar clamps to pull the trough sides together, maintaining the 12" inside spacing from end to end before fastening down the perforated top plate. You may remove the clamps once the top plate is fastened securely.

Preparing For Concrete

It is critical that concrete does not get into the AIRAUGER™ trough. Cut pieces of wood plank or plywood to fit over AIRAUGER™ perforated top plate.

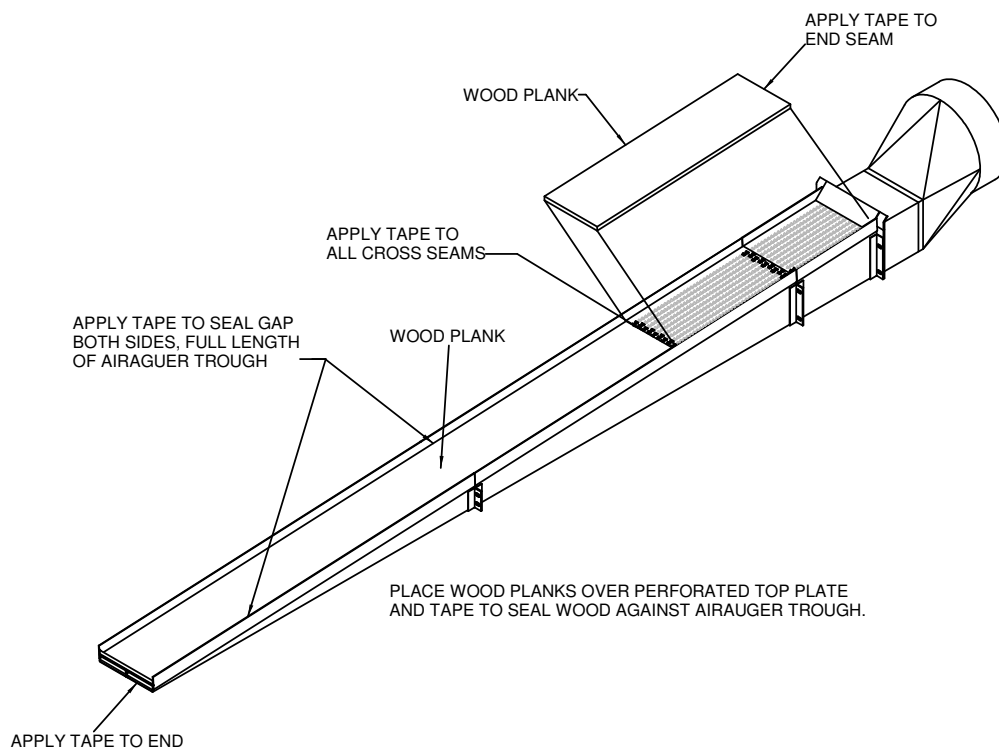

Tape all seams between the plank and the AIRAUGER™ trough, taking care not to leave any openings. Check the joint between the trough and the transition to make sure that there are no gaps. Apply tape to the discharge end of the trough, covering the cleanout slot completely and securely.

Concrete Ridges

Ridges are to be installed between the AIRAUGER™ troughs. They should be steep enough so that any grain you may handle now or in the future will slide off of the ridges and into the troughs. A minimum slope of 37° is recommended between the troughs and 45° up the wall around the bin perimeter.

The ridges are formed using concrete, with a four to six inch topcoat of sprayed-on Gunnite which is troweled to a slick finish. Gunnite is also used to form slopes at the bin walls to facilitate grain flowing down onto the troughs.

NOTE: Installing contractor is responsible for all concrete specifications and for maintaining recommended minimum slope angles.

Once the concrete work is done, remove the protective wood from the perforated top plate. Inspect the top plate for evidence of concrete entering the trough. If concrete or foreign material has entered the trough, remove the top plate and clean out the trough.



Exterior Ducting

Lay out the exterior ducting components according to the included reference drawing. Ducting parts will be numbered to match the reference numbers on the drawing.

Fasten exterior duct with the provided self-tapping screws. Enough screws are provided for approximately six screws per joint.

Take care to support all fans and ducting adequately.

NOTE: Fans and ducting are not designed to be installed without support. Consult AIRLANCO for recommendations.

CAUTION: All of the air entering the bin must be able to escape via roof exhausts. Make sure adequate roof ventilation is in place prior to operating the system.



Feeder Systems

Installations in larger bins may require a feeder system to reach the outlet sump. A feeder system may consist of various configurations of feeder and discharge troughs.

The discharge troughs are installed nearest the bin outlet sump. The discharge trough requires a continuous flow of air, and so requires a separate fan. Feeder troughs then feed material to the discharge trough, which in turn takes the material to the outlet sump.

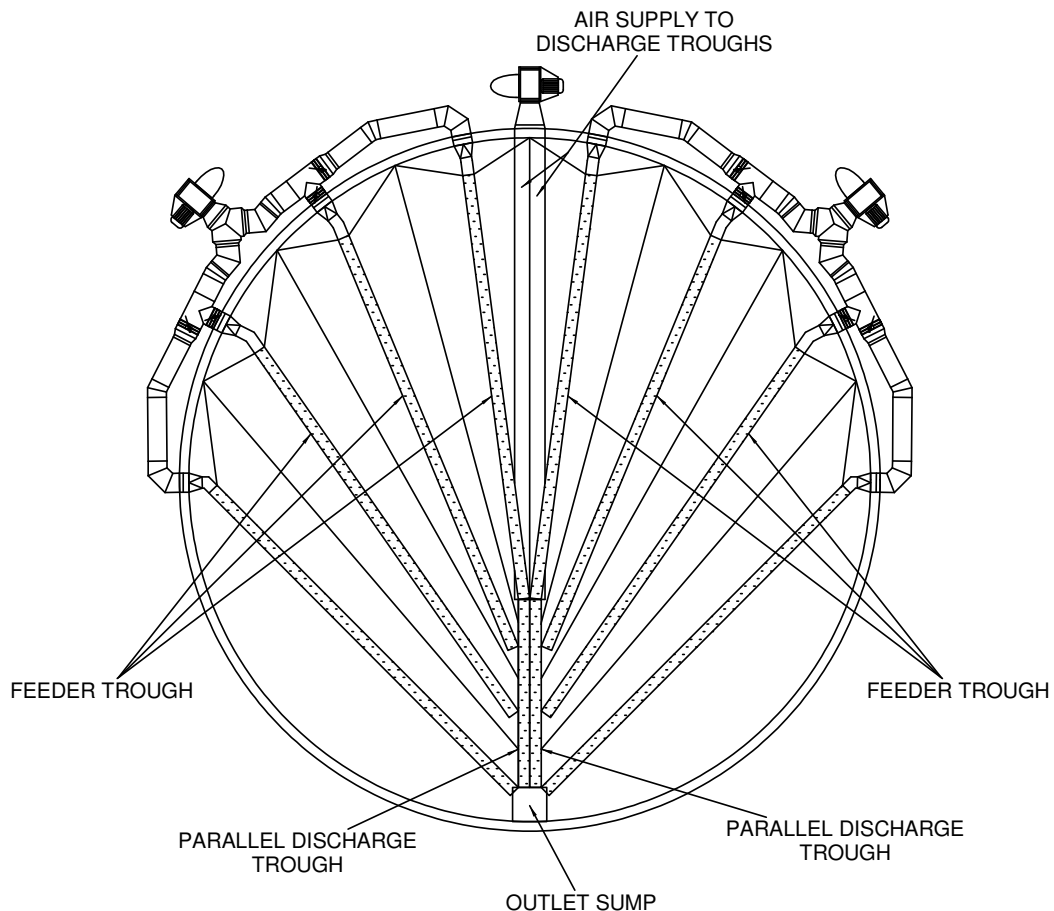

Note that the feeder trough must be high enough to clear the discharge trough's steel side wall.

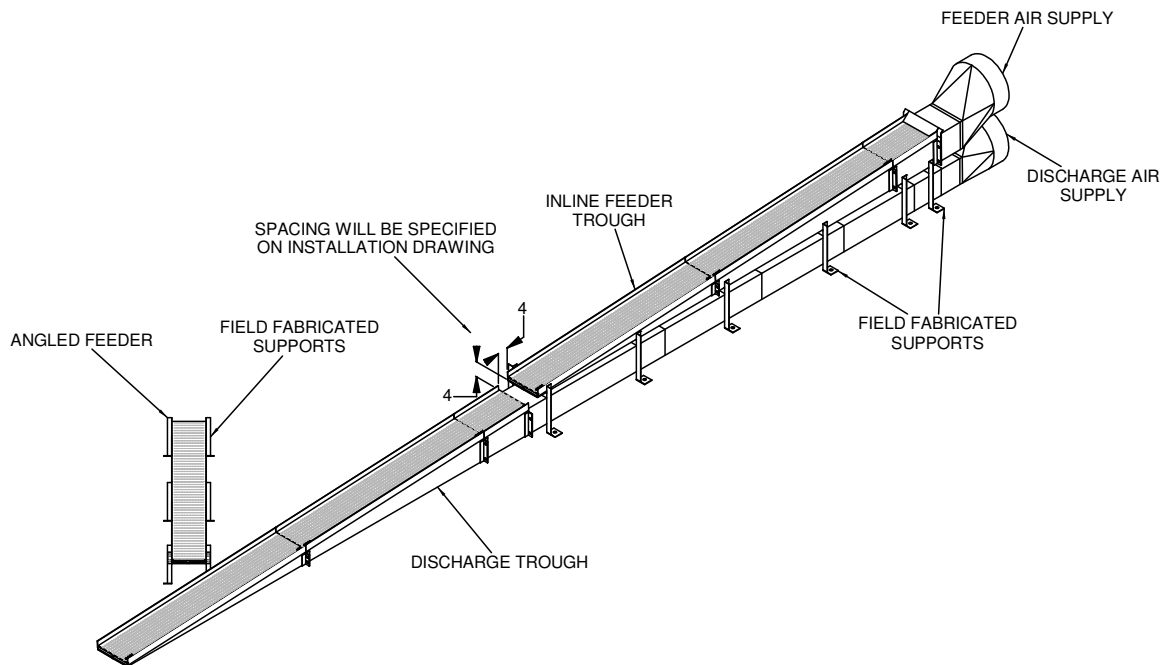

NOTE: The bottom of the feeder trough must be level.

The system installer will need to support the feeder trough so that it remains firmly in place while the concrete work is being completed. The trough must be supported under each joint, and also in the center of the length of each trough section. Welded angle iron supports are recommended. Supports are not provided by AIRLANCO. A suggested support is shown below.

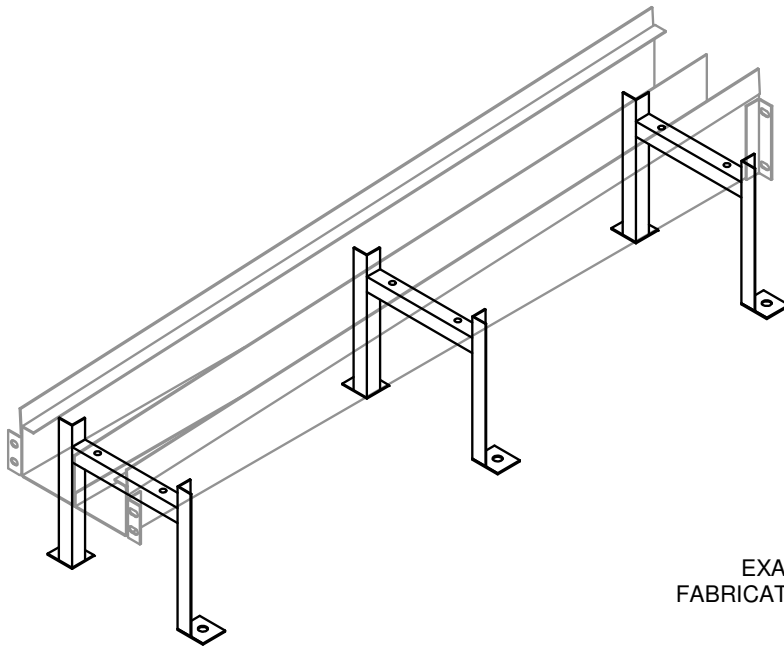

EXAMPLE OF
FABRICATED SUPPORTS

Parallel Discharge Troughs

Certain applications, such as a large diameter bin with a side draw, require the discharge capacity of two discharge troughs. In these cases, parallel discharge troughs are typically used (see illustration on page 13).

The parallel troughs are assembled in the normal manner, and the sections bolted together as usual.

Tack weld the trough joints together only on the side of the trough that is to be joined, then remove the flanges on that side.

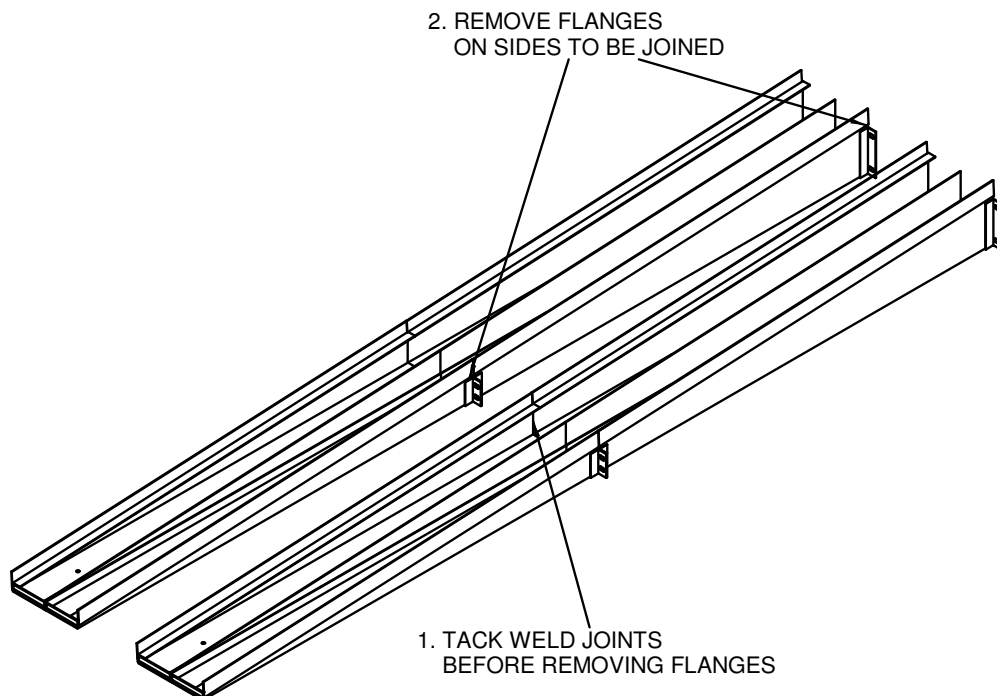

Slide the troughs together and stitch weld them together along the entire length of the parallel trough section.

Once the troughs have been welded together and are in position on the bin floor, anchor them to the floor with concrete expansion anchors.



Operating The System

Filling bins

When filling empty bins, it is recommended that the AIRAUGER™ system runs in aeration mode until the bin floor is covered with product. This is done to prevent excessive dust buildup in the troughs. The fans can be shut off once the floor is covered.

Aeration

Aerating with the AIRAUGER™ system requires three steps.

1. Turn on all powered roof exhausters on the bin or bins to be aerated.
2. Open the butterfly valves to the bin or bins that you wish to aerate. To ensure even aeration, it is important that all of the butterfly valves are open to each bin that you wish to aerate.
3. Start the fan or fans to begin aerating.

NOTE: It is important to remember to start up the roof ventilation prior to turning on the AIRAUGER™ system fan or fans.

Bin unloading

Empty the bin as you normally would until the product stops flowing by gravity. Do not start the AIRAUGER™ system until the product stops flowing. Start up roof ventilation on the bin to be emptied.

Open one butterfly valve to release the air to one trough, then start the AIRAUGER™ system fan. When the product stops flowing, close the butterfly valve and open another butterfly valve to empty another trough. Repeat these steps until all troughs are empty.

Once the bin has been completely emptied, you may want to open each butterfly valve in turn to make sure that the cleanout is complete.

NOTE: Follow industry standard best practices and bin manufacturer's recommendations for emptying bins.

If you have any questions concerning system operation, please contact your AIRLANCO representative at 800-500-9777.

Installation Completion Checklist

- ❑ Drawings available showing parts and reference numbers.
- ❑ Bin floor sufficiently flat and clean.
- ❑ All parts accounted for and located on reference drawing.
- ❑ Narrow ends of troughs proper distance from bin discharge.
- ❑ Troughs anchored securely to bin floor.
- ❑ Perforated top plate installed **smooth side up**.
- ❑ Perforated top plate **overlaps in proper direction**.
- ❑ Perforated top plate completely free of any concrete material.
- ❑ Troughs completely free of any debris.
- ❑ No gap between trough and air inlet transition.
- ❑ Concrete ridges at minimum angle or greater at all points.
- ❑ Exterior ducting joints sealed, caulked and secured with screws.
- ❑ Exterior ducting and fans adequately supported.
- ❑ Exterior ducting valves operating freely.